

Without written authorization from Zhongshan Ueleret Smart Image Technology Co.,Ltd. ,any form of complete or partial replication of this manual is strictly prohibited (except for simple quotations for article or comment evaluation purposes).

July 2024



## Installation and use manual of Remote Camera Assistant mini

### Nikon version

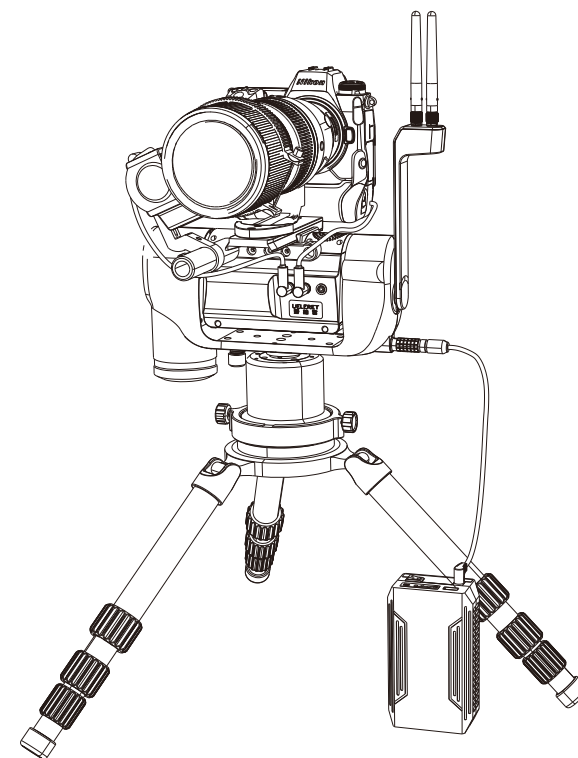

Zhongshan Ueleret Smart Image Technology Co.,Ltd.

Address: Room 306, C area, 3rd floor, Building 7, Zhangqi Technology Incubator,  
No.70 Zhongshan Gang Road, Torch Hi-tech Industrial Development Zone,  
Zhongshan City, Guangdong, China.

Address: NO.10 Yiwei Road, Torch Hi-tech Industrial Development Zone,  
Zhongshan City, Guangdong, China. Post code: 528437

Phone: 0086-0760-89878172

Website: [www.ueleret.com.cn](http://www.ueleret.com.cn)

© 2023 Ueleret Smart Image Technology Co., Ltd.

## Preface

Thank you for your trust in choose UELERET Remote Camera Assistant mini.

We will serve wholeheartedly for you.

The Remote Camera Assistant mini is a highly integrated smart device that controls digital camera shooting and smart gimbal movement through a handle and tablet. When the transmission signal is unblocked or slightly blocked, the distance between the camera and the operator can be 0-500 meters or 0-1000 meters.

1. This manual applies to the following products Remote Camera Assistant mini (wireless communication distance 500 meters)

Remote Camera Assistant mini 1000 (wireless communication distance 1000 meters)

2. The user pays to download the firmware from the official website of UELERET and purchase the communication package to upgrade to the Remote camera assistant mini 1000.

3. The above products are installed in the same way.

In order to ensure that you successfully use the Remote Camera Assistant mini product, please read the instructions carefully and master the operation proficiently.

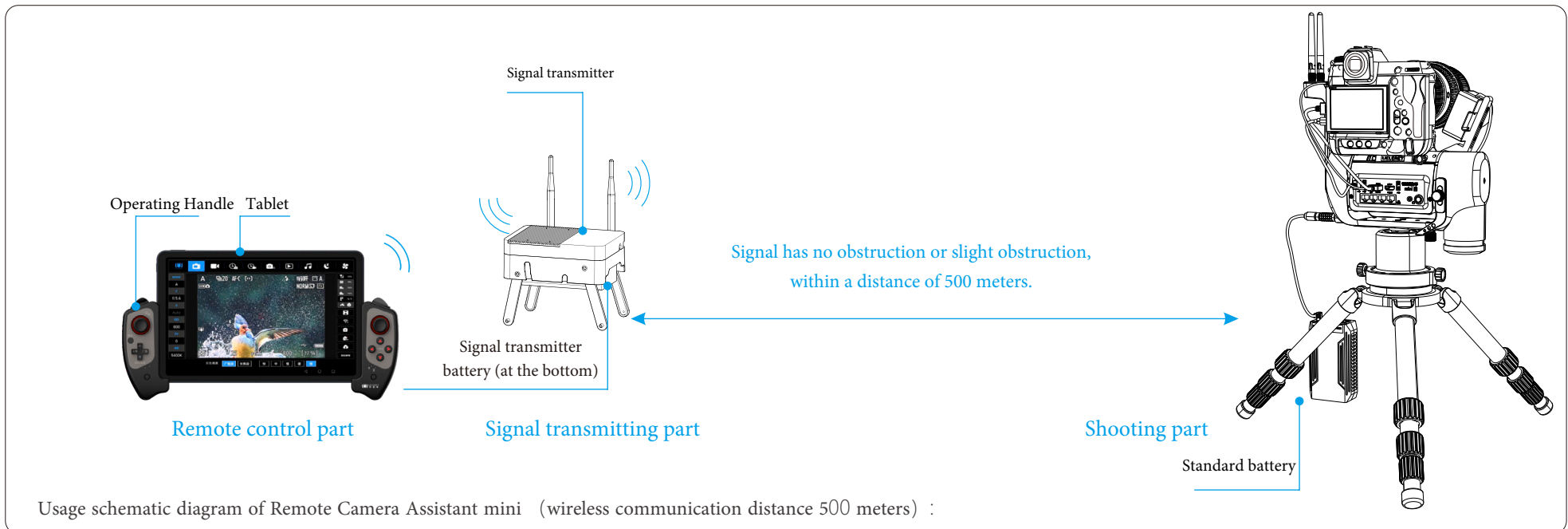

# Content

Chapter 1. Product Structure and parts introduction of Remote Camera Assistant mini	
I Structure diagram of smart gimbal.....	1
II Name of each parts of Remote Camera Assistant mini.....	2
III Each interface functions of smart gimbal.....	3
IV Lens zoom controller accessories.....	4
V Parts functions introduction of Remote Camera Assistant mini.....	5
Chapter 2. Installation of Remote Camera Assistant mini——Wired control the mirrorless camera	
I. Prepare in advance, inspect items and pack neatly (Recommended, Develop a Habit).....	13
II. Site Survey and Selection for Shooting (Strongly Recommended, Develop a Habit).....	14
III. Installation steps of smart gimbal	
Case 1: Installing the smart gimbal on a hard floor	
1. Mount the shooting direction base on the tripod.....	15
2. Mount the smart gimbal on the shooting direction base .....	15
3. Install the lens zoom controller.....	16
4. Attach the zoom ring to the camera lens.....	18
5. Mount the camera to the smart gimbal.....	18
6. Install the camera battery converter.....	19
7. Installation the cable.....	19
8. Screw the antennas clockwise to the corresponding interfaces on the gimbal.....	21
9. Move the lens zoom controller.....	21
10. Ensure a tight fit between the lens zoom controller and the camera lens zoom gear.....	22

Case 2: When the smart gimbal is installed on water or in a muddy place	
1. Install the shooting position base.....	23
2. Place the smart gimbal on the car seat or on the hard ground.....	23
Chapter 3. Installation of Remote Camera Assistant mini——Wired control the DSLR camera	
I. Viewfinder camera introduction and illustration.....	23
II. Installation of Viewfinder camera.....	24
Chapter 4. Installation of RCA mini——Wireless control the mirrorless camera	26
Chapter 5 On-site debugging of the smart gimbal	27
Chapter 6 On-site preparation for remote shooting	27
Chapter 7 On-site debugging of the Remote camera assistant for remote shooting	28
Chapter 8 Power-saving operation and sleep mode settings for RCA mini	28
Chapter 9 Safety precautions for the remote camera assistant mini	30
Chapter 10 Product specifications	33
Chapter 11 Power supply specifications and maintenance	
1. Battery specifications and parameters list.....	35
2. Battery usage time table.....	36
3. Battery solution introduction.....	36
4. Battery usage precautions.....	37
Chapter 12 Wireless communication	38
Chapter 13 Product certification and compliance	39
Chapter 14 Remote camera assistant mini 1000m version	41

## Chapter 1. Structure and parts introduction of RCA mini

The contents of this chapter are introduced using the Remote camera assistant mini ( 500 meter communication distance) product as a model.

### I . Structure diagram of smart gimbal

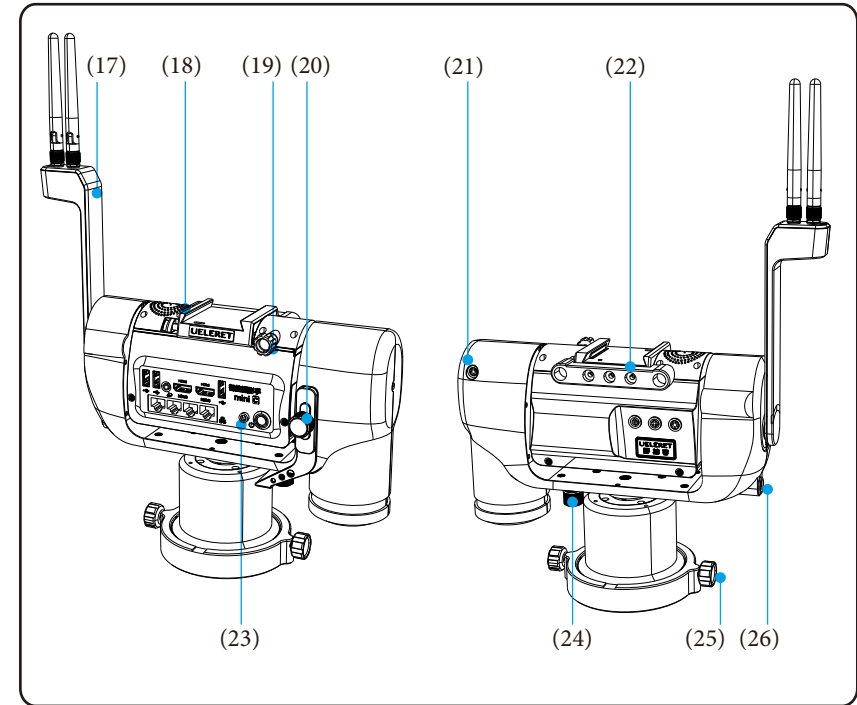
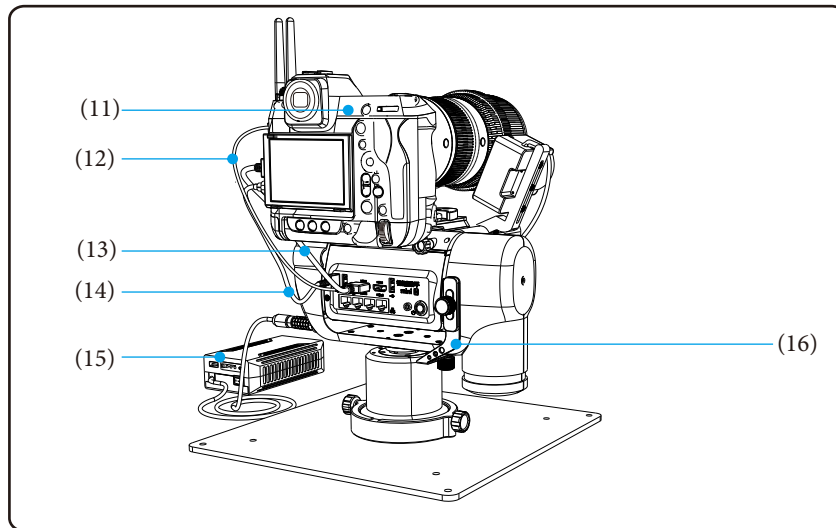
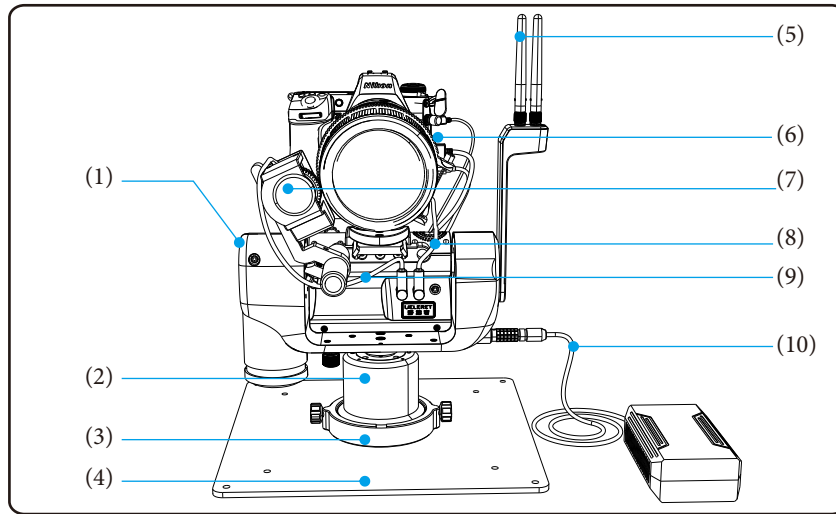

### II . Name of each parts of Remote Camera Assistant mini

- |  |   |   |
|--|---|---|
| 1. Smart gimbal                        | 11. Digital camera (not included)                             | 21. Trail camera information and power connection interface |
| 2. Rotary support base                 | 12. USB cable(left first port)                                | 22. Lens zoom fixed base                                    |
| 3. Shooting direction base             | 13. Shutter release base                                      | 23. Signal light  |
| 4. Low position camera board(Optional) | 14. HDMI cable(left first pot)                                | 24. Thumb screw below the cable clamp                       |
| 5. Small antenna                       | 15. Standard battery  | 25. Thumb screw for shooting direction base                 |
| 6. Zoom ring                           | 16. Cable clamp (non-standard)                                | 26. Gimbal power interface                                  |
| 7. Lens zoom controller                | 17. Antenna bracket   |   |
| 8. Camera power cable                  | 18. Loudspeaker support base                                  |   |
| 9. Lens zoom controller power cable    | 19. Quick release plate fastening thumb knob                  |   |
| 10. Gimbal power cable                 | 20. Thumb screw on the side of the cable clamp (non-standard) |   |



### III. Each interface functions of smart gimbal

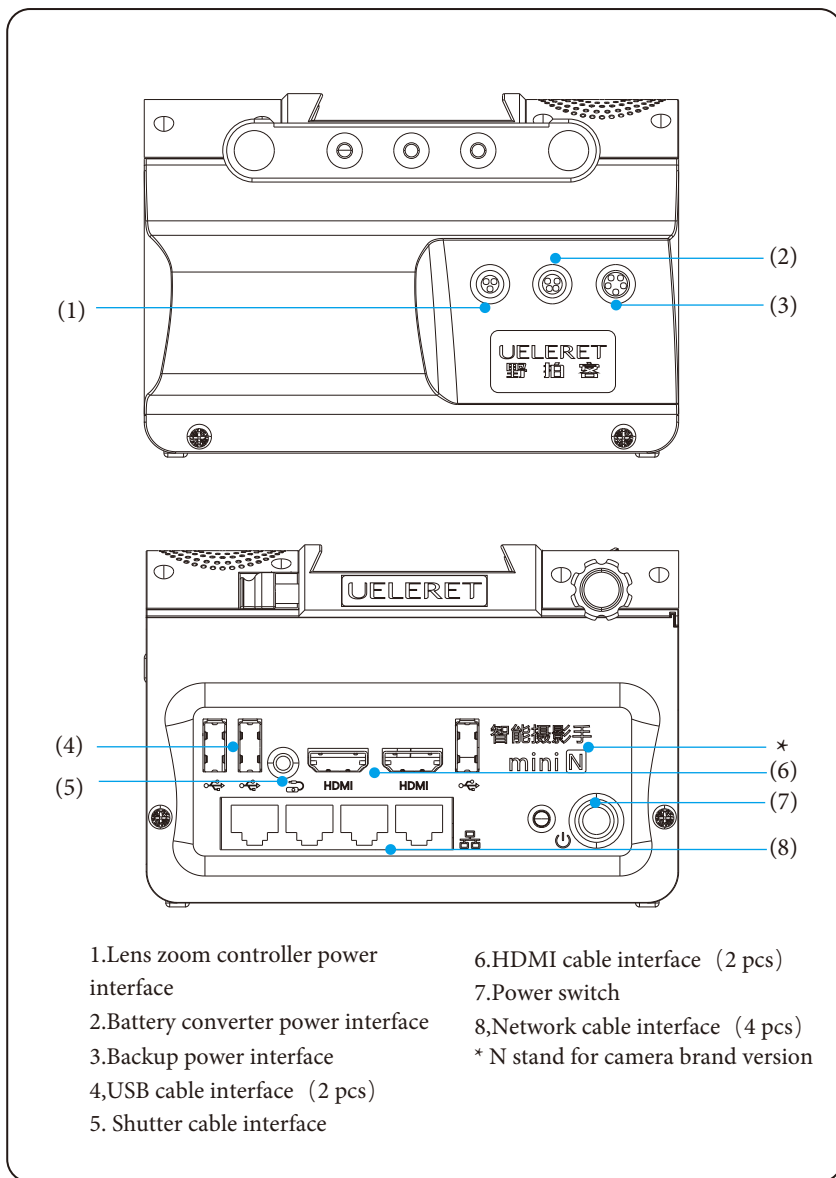

### IV. Lens zoom controller accessories

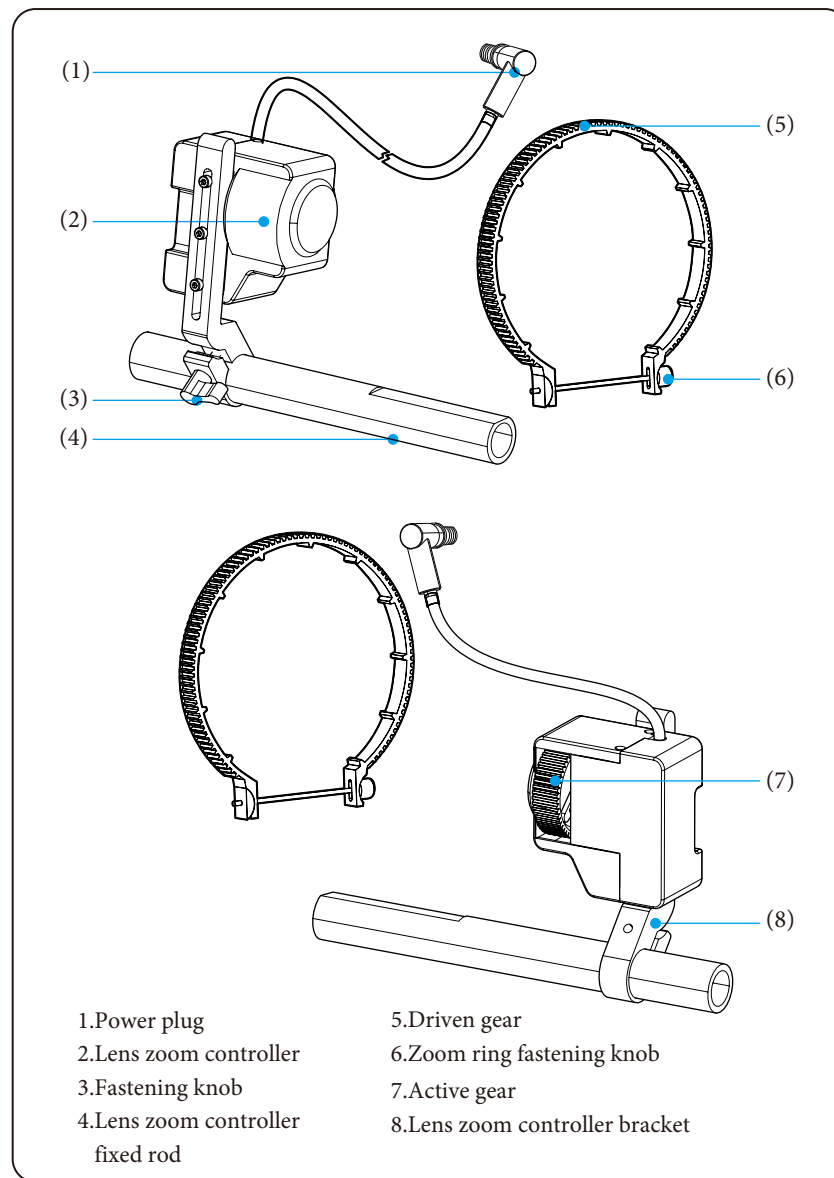

## V. Functions introduction of Remote Camera Assistant mini

### 1. Smart gimbal

- (1) Normal erection, pitch angle: 22° down, 40° up (horizontal balance is 0° .  
Rotation angle: leftward 130°, rightward 130° .;
- (2) Weight of gimbal: ≈ 2.3KG
- (3) Load capacity: <4.2KG

### 2. Lens zoom controller accessories

- (1). After using the Remote camera assistant mini, the frequency of using the zoom lens on the digital camera will significantly increase. Photographers can capture shots of animals while keeping a safe distance, allowing the animals to move around with greater peace of mind and up close to the digital camera. Using the zoom lens enables adaptation to various situations.
- (2). The lens zoom controller is used to drive the expansion and contraction of the zoom lens, enabling lens zooming.
- (3). The zoom ring installed on the zoom lens comes in various specifications (depending on the diameter of the lens).
- (4). The compatible zoom rings for different lens models are listed in the table below:

Zoom Ring (Recommended)	Nikon Lens model	Zoom Ring (Recommended)	Nikon Lens model
Inner diameter 40-84mm Soft zoom ring	AF-S 14-24mm f/2.8G ED	Inner diameter 90mm	AF-S 70-200mm f/2.8E FL ED VR
	AF-S 24-70mm f/2.8E ED VR		AF-S 80-400mm f/4.5-5.6G ED VR
	AF-S 24-120mm f/4G ED VR		Z 28-400mm f/4-8 VR
	AF-S 28-300mm f/3.5-5.6G ED VR	Inner diameter 100mm	Z180-600mm f/5.6-6.3ED VR

#### Notes:

1. Soft zoom ring: Inner diameter 40-84mm. When using small-body cameras with medium-short focal length lenses, these lenses do not have lens brackets, and the quick-release plate is mounted on the bottom of the camera body. If a hard material zoom ring is used, it may collide with the quick-release plate during zooming. This issue can be avoided by using a soft material zoom ring. You can download a detailed demonstration of installing short focal length lenses on the official website.
2. After installing the battery grip and handle on the camera, the height of the camera body increases, allowing the use of a hard material zoom ring.

3. Even the total weight of the camera body and lens is within 4.2 kg, if the lens is too long, it will affect the balance of the gimbal. Insufficient pitching force may occur during tilting, making it unable to drive the zoom function. Therefore, please consider carefully whether to use a large zoom lens.
4. When using a fixed lens, the lens zoom controller can be used as a focus controller, similar to manual focusing.
5. Manual focusing is used in the following situations:
  - (1) When shooting subjects with very weak background contrast or minimal color differences, the auto focus function may have difficulty distinguishing and focusing accurately.
  - (2) When the subject to be focused on is being interfered with by other objects, making the auto focus function be difficult to accurately focus on the desired subject.
  - (3) When using a telephoto lens and the desired focal distance is significantly different from the current focal distance, the auto focus (AF) may lack sufficient driving force to achieve clear focus. In such cases, it is common to perform manual focusing to gradually achieve clarity and then switch to AF for faster and accurate focusing.

### 6. Shooting direction base

- (1) The smart gimbal has an independent battery power cable connection, communication signal transmission and other reasons, it is difficult to achieve 360° arbitrary rotation. The Remote camera assistant mini has a shooting angle of 130° to both left and right. The gimbal support base is marked with a triangle as a reference for the rotation angle of the gimbal.
- (2) When setting up a tripod in water or muddy ground, the following situation may arise: If the tripod is inserted into water or placed on muddy ground before installing the smart gimbal, it may not be possible to achieve 130° rotation angle in both left and right directions for the required shooting angle. Adjusting the direction of the tripod at that point will be quite inconvenient.

Therefore, it is recommended to install the shooting positioning base on the tripod in advance. This will provide a clear indication of the orientation of the tripod, ensuring that 130° rotation angle in both left and right directions for shooting can be achieved.

#### 4. Ruyi quick release plate instructions

Some fixed feet of Telephoto lenses have only one threaded hole. Short-focus lenses generally do not have fixed feet and are installed on the camera body, with only one screw hole at the bottom of the body for installation, which is not stable.



When a force is applied in the opposite direction of the bolt tightening, the tightened bolt is prone to rotation and loosening, which will affect the stability of the camera and lens during shooting. RCA mini needs to be installed and use the lens zoom adjuster, and the zoom rings must be tightly engaged to push the zoom gear to move.

It also requires the camera lens foot (or body) to be tightly connected to the quick release plate. If it is loose, it will affect the normal use of the RCA mini.

The three-point installation structure of the Ruyi quick release plate can prevent the quick release plate from loosening

##### (1). Picture of Ruyi quick release plate

The Ruyi quick release plate is fixed at three points to ensure that after the quick release plate is connected to the lens support and the camera body, it will not loosen even if it is pushed by lateral force.

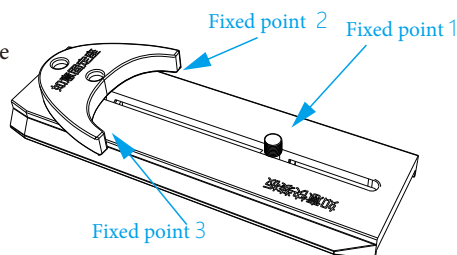

##### (2). Ruyi quick release plate installation Ruyi quick release plate has two installation methods: Install in front and in the back

The camera is equipped with a short-focus lens, and the quick-release plate is installed from the back. (The Ruyi fixing buckle is behind the camera)

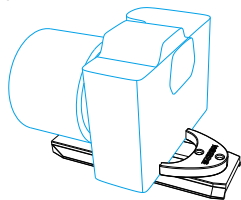

The camera is equipped with a telephoto lens or a lens tripod ring, and the quick-release plate is installed from the front (the Ruyi fixing buckle is in front of the camera)

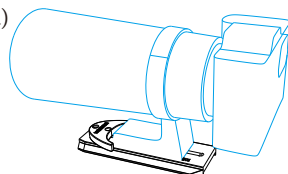

#### 5. Power supply battery

(1) The Remote camera assistant mini requires two batteries. Both is the standard battery (24V 82.88Wh), and comply with boarding requirements.

(2) One is used to power the smart gimbal, and the other is used to power the signal transmitter.

(3) Large capacity batteries are available:

Battery model UB01, It cannot be remotely monitored for battery level and is not suitable for air travel. It is more affordable and convenient for carrying during car trips for photography purposes. The battery level displayed on a tablet will always show 50% regardless of the actual battery level until it is completely depleted, at which point it will display 0.

##### Battery Usage Time:

(1)With a standard battery, the standby time of the smart gimbal is 4-4.5 hours; uninterrupted operation of equipment and shooting can meet the power supply of 2-2.5 hours

(2)With large-capacity battery or smart battery pack, the standby time of the smart gimbal is about 20 hours, and the uninterrupted operation of equipment and shooting can satisfy

##### 11-13 hours of power supply

(3)There are many factors that affect the battery life, so the marked time is interval data.

(4)The Remote camera assistant mini has a power-saving sleep mode. During sleep mode, the gimbal stops working, and only the power required for restarting the gimbal is retained, with no communication signals transmitted. When the sleep time ends, the gimbal will automatically power on and resume operation. For specific instructions, please refer to the "Power-saving operation and sleep mode settings for the Remote camera assistant mini" section.

#### 6. External camera battery converter (Optional)

(1) List of Canon camera models compatible with the power converter.

(2) When using the camera's original battery, it may not guarantee sufficient battery life. Having to replace the battery on-site during a shoot can disturb animals and disrupt the planned photography session.

(3) By using the power supply from the smart gimbal, the insufficient battery life of the camera can be resolved. We offer camera battery converters for different camera models.

Camera Model	Battery Converter Model
Z9	U/EP-9
Z8、D850、D500	U/EP-5B

This product comes with the battery converter of Z8 as standard; other models need to be purchased separately.

The installation of the Nikon Z9 camera battery converter is shown in the diagram below:

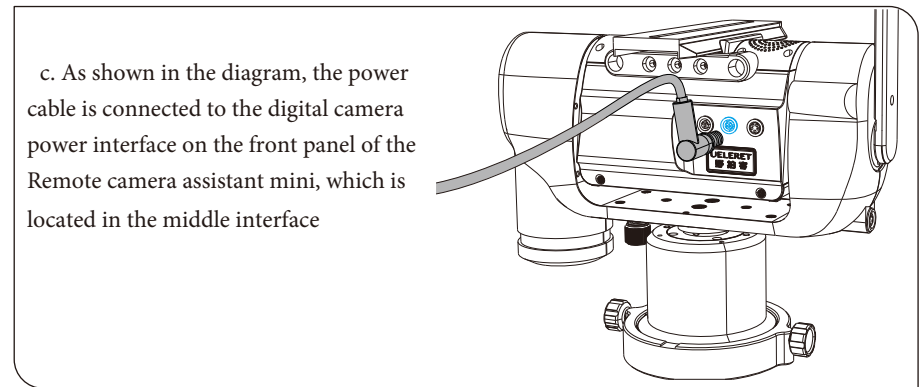
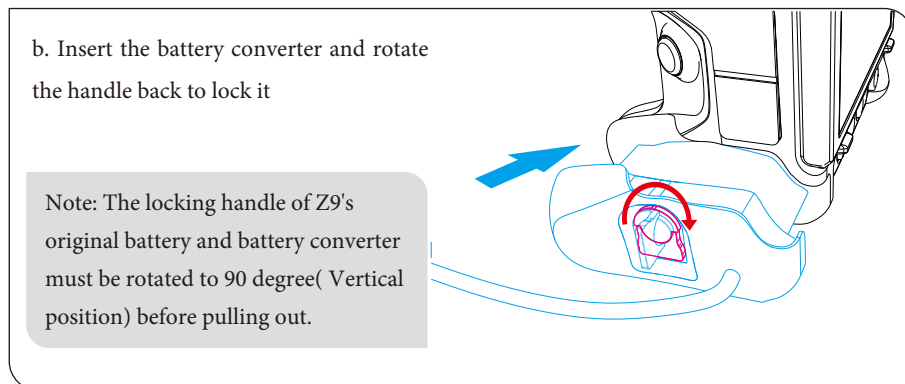
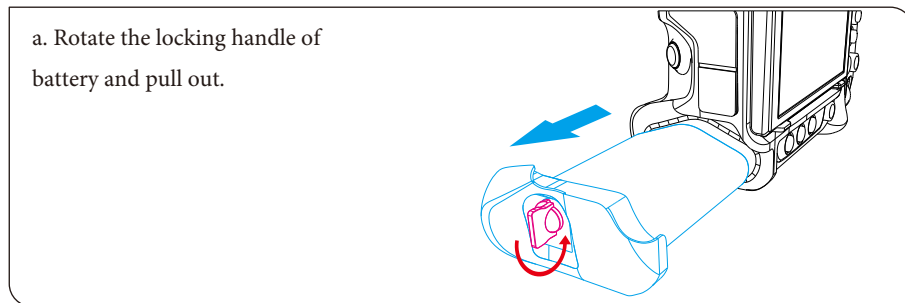

## 7. Antenna

(1) Include 4 antennas

(2) They are used for wireless signal transmission between the smart gimbal and the controller.

(3) 2 antennas are installed on the smart gimbal, and the other two antennas are installed on the signal transmitter.

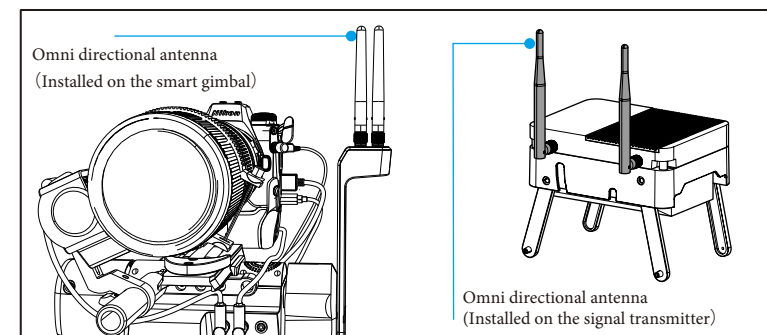

## 8. One set of cables

(1) The camera battery converter and lens zoom controller each come with 1 cable, while the power supply cable for the smart gimbal is a separate cable.

(2) The data cable and shutter cable required for the camera are grouped together.

(3) The connectors for the cables have unique shapes and a single interface, making them easy to connect without the need for special markings.

### 9. Signal transmitter

(1) After removing the signal transmitter from the packaging box, insert the power cord plug located on the side of the signal transmitter panel into the battery discharge port at the bottom (as shown in Figure 1). Then, turn on the battery switch (as shown in Figure 2). The signal transmitter will work.

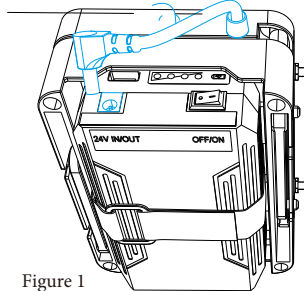

Figure 1

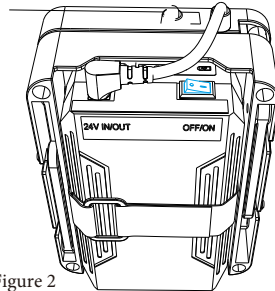
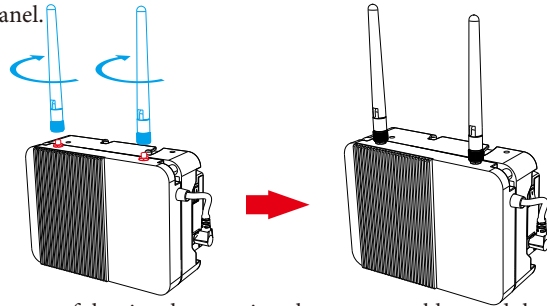
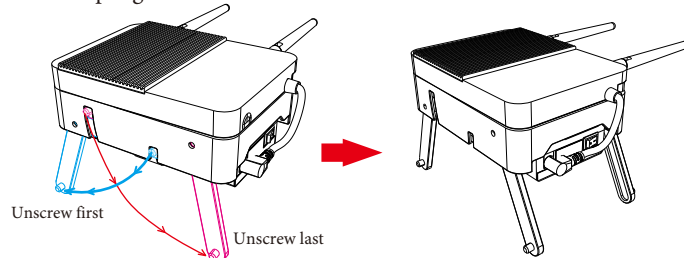

Figure 2

(2). Screw the two antennas into the two protruding screw positions on the top of the signal transmitter panel.



(3). The bottom of the signal transmitter has a retractable stand that can be opened and placed on the ground or at a high position. First, extend the shallower grooved stand, then extend the deeper grooved stand. The other side's stand is extended in the same way.



(4) Bend the signal transmitter's antennas 90° upwards so that the omnidirectional antennas point towards the sky.

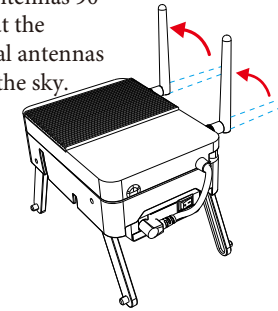

(5) The signal transmitter has a back rope that can be used to tie it to objects hanging high up, such as tree trunks.

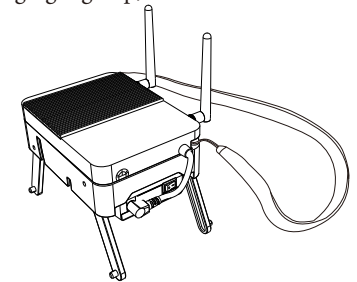

(6). Use the signal transmitter near the handle operation end, transmitting the signal received by the antennas to the tablet and the operation handle.

(7). The signal transmitter can be separated from the operation handle and the tablet. In an unobstructed environment, the separation distance should not exceed 100m. Beyond 100m, the wireless signal weakens, reducing signal strength and affecting the operation of the tablet and handle.

(8). The operation handle and the tablet are connected via Bluetooth.

(9). Mount the signal transmitter as high as possible to reduce communication signal blockage. When the distance between the signal transmitter and the camera exceeds 300m, ensure that the signal transmitter is at least 1m above the ground.

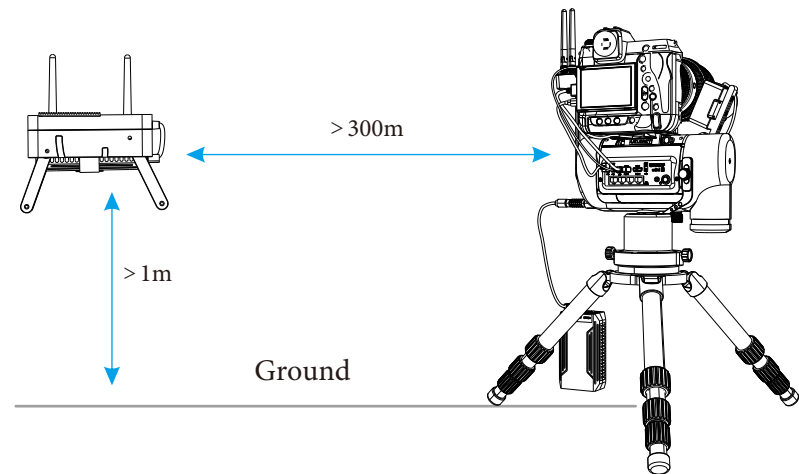

10. Operating software (Android system)

11. Operating Handle

\*Note: For details on items 9 and 10, please refer to the "Software operation and camera function setting instructions of RCA mini" (Nikon version) for more information.

## Chapter 2: Installation of RCA mini-Wired control mirrorless camera

### I . Prepare in advance, inspect items and pack neatly

(1) The User must ensure that the batteries are charged in advance. Before setting out for a shoot, check the battery levels of various devices to ensure they are sufficiently charged.

- ① Battery level of the tablet/phone.
- ② Battery level of the power source for charging the tablet/phone (e.g., power bank).
- ③ Battery level of the signal transmitter, smart gimbal, operating handle etc..

(2) If you need to use a zoom lens for this shoot, it is recommended to install the zoom ring securely on the lens in advance. This will save time during the on-site setup. Please refer to the diagram below:

①. Choose a soft or hard zoom ring according to the lens. When using a medium-short focal length lens, it is recommended to use a soft zoom ring.

②. When using a medium-long focal length lens, it is recommended to use a hard zoom ring. As shown in the diagram, remove the zoom ring locking screw and place the zoom ring on the zoom ring barrel of the camera lens and tighten it.

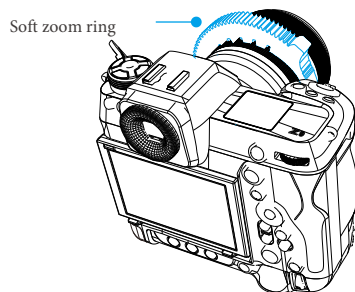

\* When installing the zoom ring, it is important not to over tighten it. If it is excessively tightened, it can cause deformation of the circular shape, resulting in poor zoom operation. The zoom adjuster may have difficulty driving the zoom, produce loud noises, or even fail to operate the zoom.

\* How can you determine if the tightness of the zoom ring installed on the zoom lens is appropriate? After installing the zoom ring, try rotating the lens by hand. It should have a similar tightness as when the zoom ring was not installed.

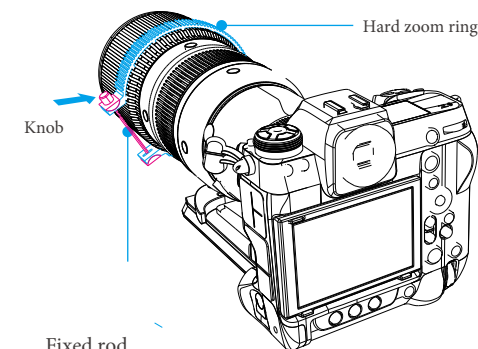

Fixed rod  
When using a quick-release plate, the zoom ring locking screw needs to be installed on the right side of the lens, ensuring that it does not interfere with the mounting bracket of the quick-release plate during zooming.

- ③. Before departure, it is recommended to pre-install the camera quick-release plate to save time during on-site setup.
- ④. Set the desired mode on the camera in advance, such as AF-C mode. This function is manually switched on the camera and cannot be controlled by the software.
- ⑤ Check all components and connections to ensure nothing is missed, and pack everything properly for quick and efficient transportation.

### II .Site survey and selection for shooting

1. Clearly define the shooting objectives for this session and carefully observe the shooting location. Determine the placement position for the smart gimbal and the desired location for operating the handle or parking the car.
2. Based on the shooting scene and subject, first choose the placement point for the tripod and determine the desired height for the tripod support.
3. It can be inconvenient for user to install the smart gimbal and camera first, and then search

### III . Installation steps of smart gimbal

The installation of the Remote camera assistant mini can vary depending on the shooting location, such as different installations for hard land surfaces and water or muddy areas.



Case 1: Smart gimbal installed on a hard floor Step

1. Mount the shooting direction base on the tripod.

Note: When installing on a hard floor, it may not be necessary to use the shooting direction base. However, it is still recommended to install the shooting direction base on the tripod or low-level shooting board as it provides more convenience during equipment setup.

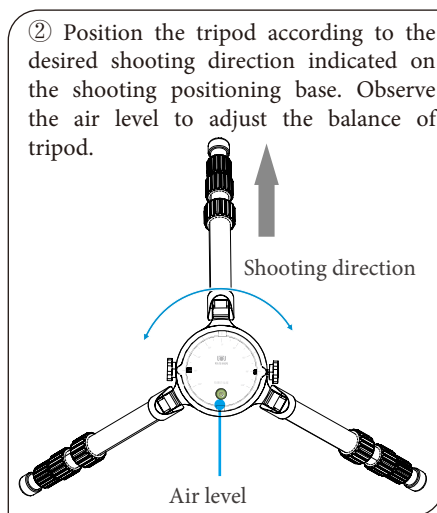
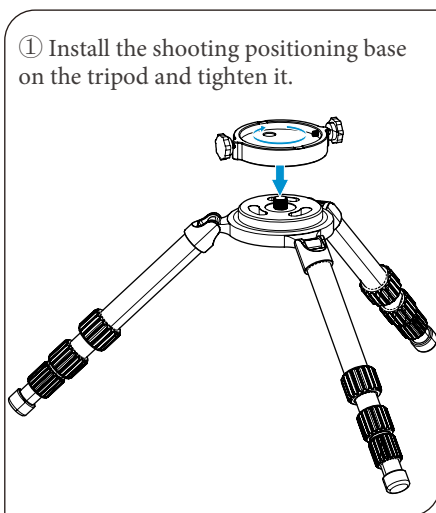

Step 2. Mount the smart gimbal on the shooting direction base.

Align the square portion on the gimbal support base with the part on the shooting positioning base. Mount the gimbal on the base and tighten the locking knob. (Note: The side of the gimbal with the triangular symbol should be facing away from the subject). Rotate the gimbal until the positioning markers (two triangles) are aligned, ensuring that the shooting angle is in the desired direction. Otherwise the smart gimbal will not be able to achieve a 130° rotation to the left and right.

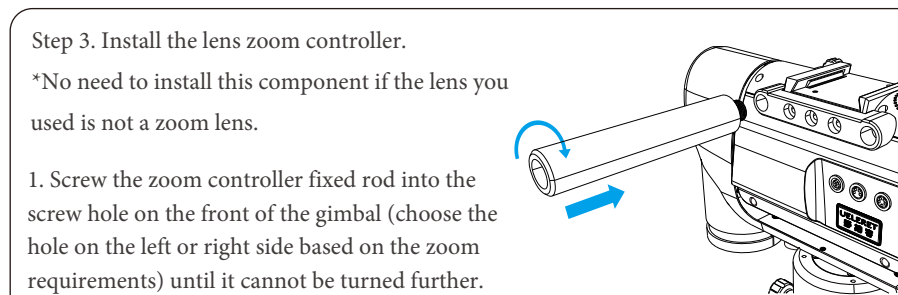
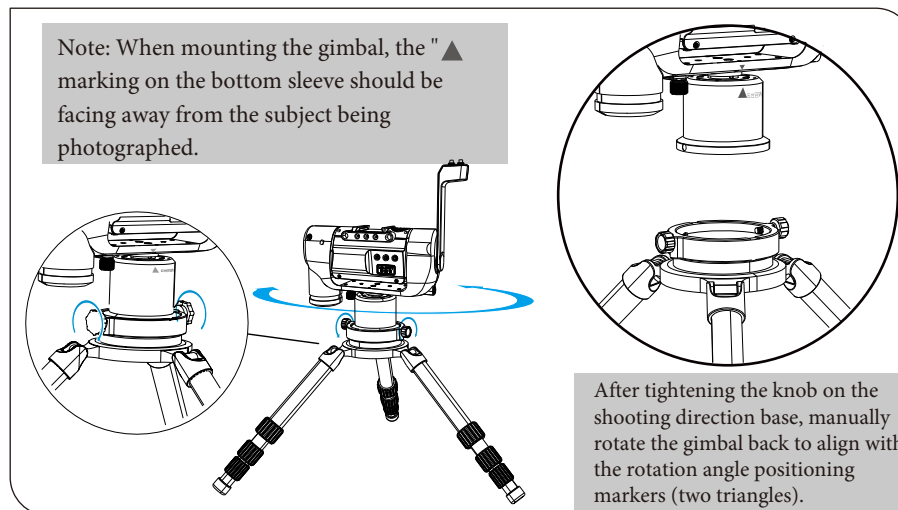
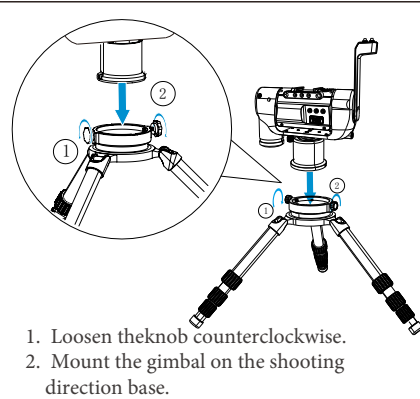

Note: There are two different installation methods of the lens zoom controller according to the distance between the lens zoom ring and the gimbal.

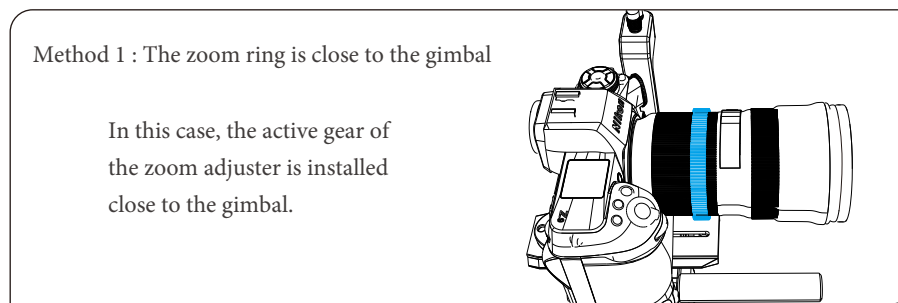

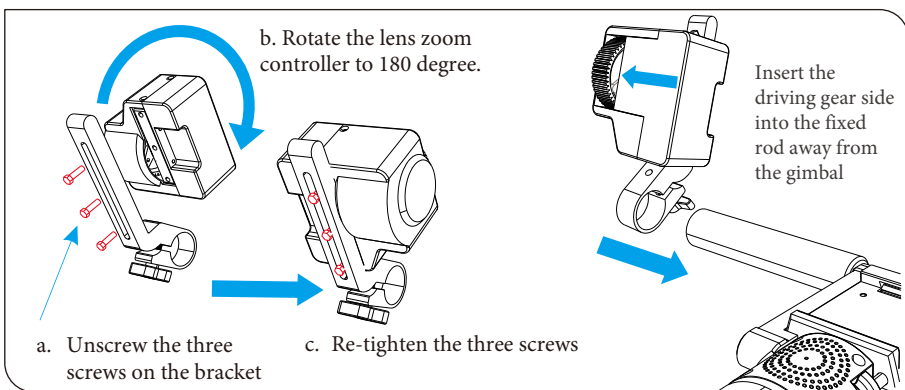
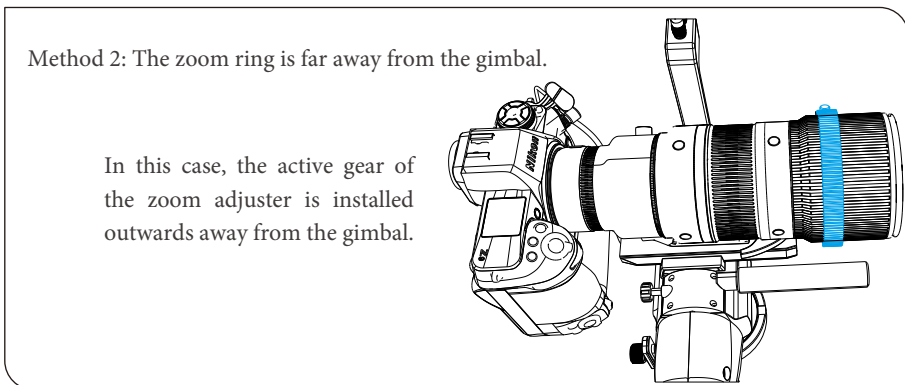
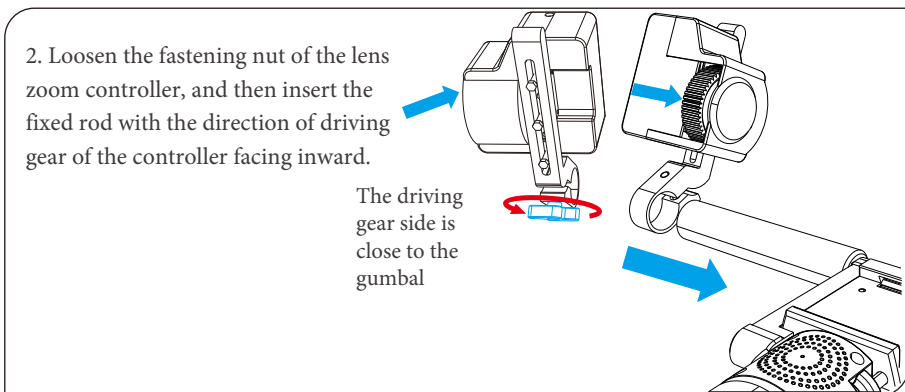

Z9 is usually worked with medium long length lenses. The zoom ring is far from the camera, the installation of zoom controller will be installed with the method 2.

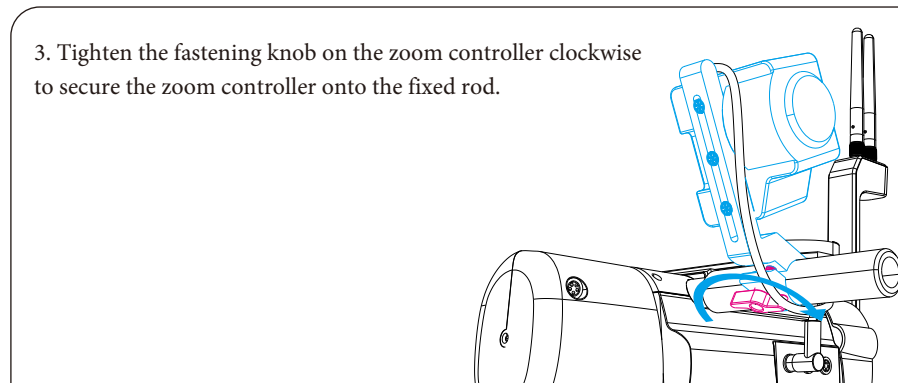

4. Attach the zoom ring to the camera lens.

This step is not necessary if it was already installed in advance or if using a fixed lens.

5. Mount the camera onto the smart gimbal.

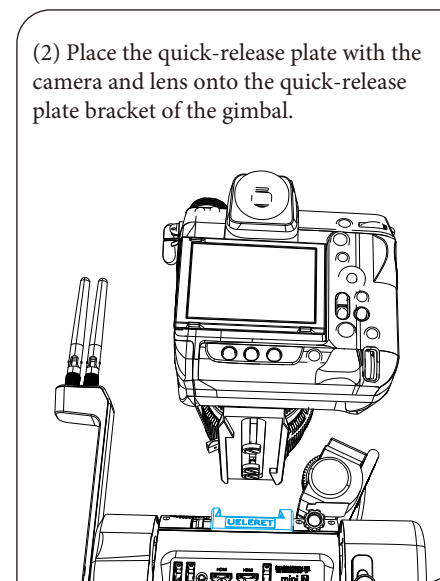
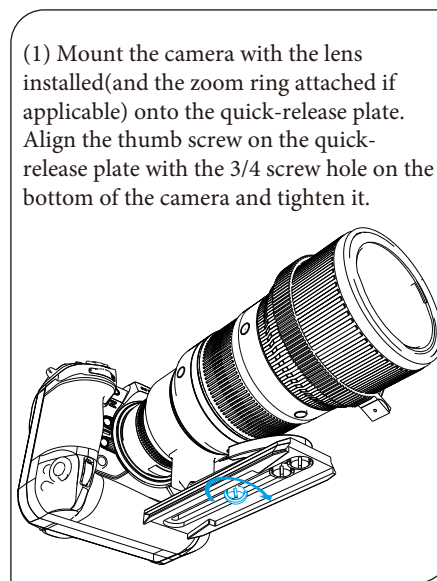





6. Install the camera battery converter  
(No need this step if using the camera's original battery.) Please refer to Chapter 1, Point 7 for the specific installation of the camera battery converter.

Note: The shooting time may be limited when using the camera's original battery, due to battery capacity.

7. Connect the cables

(1) Available cables for Nikon version.



Camera models	Qty	Cable	Gimbal side	Camera side	Length
Z9、Z8	1	HDMI	HDMI A	HDMI A	0.35-0.4m
	1	USB	USB	USB Type C	0.35-0.4m
	1	Shutter cable	3.5mm port	N1 shutter port	0.35-0.4m

This product comes with Z9 and Z8 data cables

2. Match and connect the cables according to the markings on the main control board.

Using Nikon Z9 camera as an example:

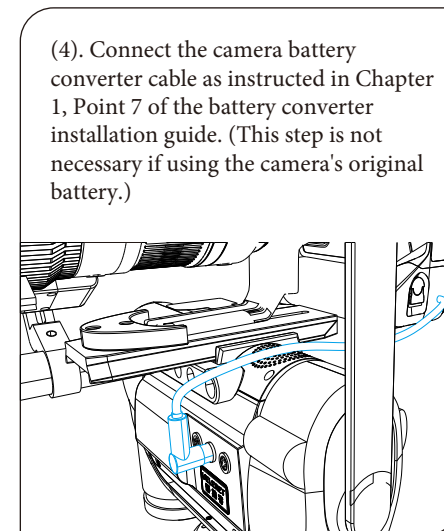
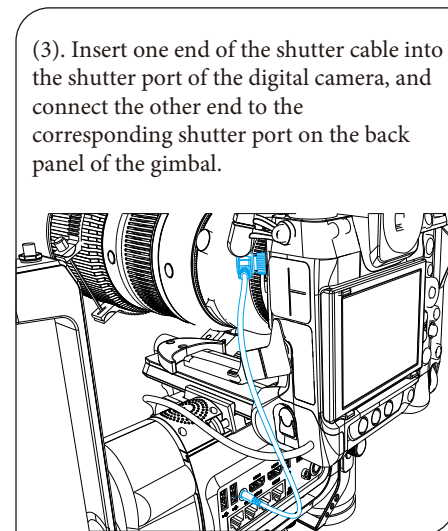
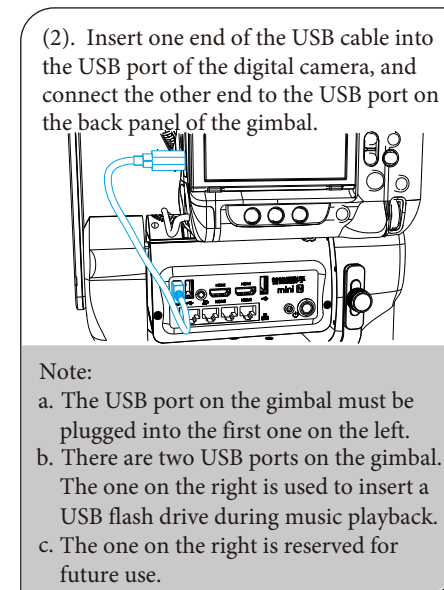
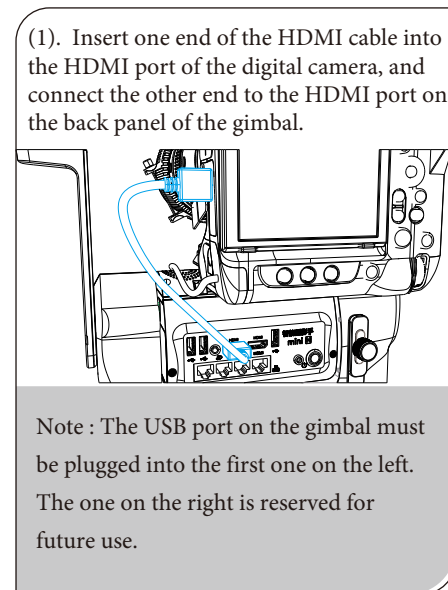

(5). Connect the power cable of the lens zoom controller to the power port on the front panel of the gimbal.  
See the diagram for the location, the first one on the left.

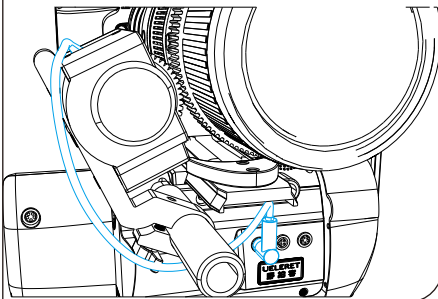

(6). Connect the power cable of the standard battery, with one end inserted into the battery interface on the side of the gimbal and the other end plugged into the 24V output port of the standard battery.

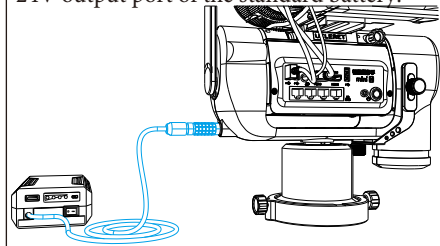

Note: When connecting the power cable to the gimbal's power interface, make sure to align the directional markings on the interface before insertion.

Step 8. Screw the two antennas clockwise onto the corresponding interfaces at the top of the gimbal antenna arm.

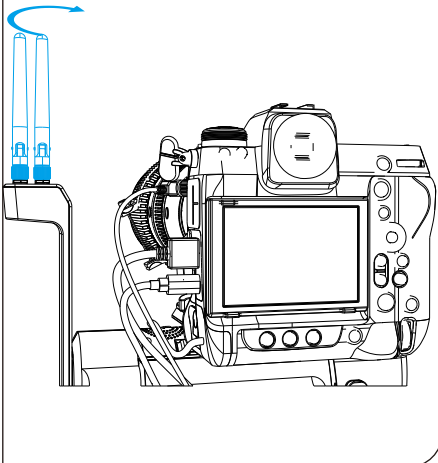

Step 9. Move the lens zoom controller.  
Align the teeth on the adjustment wheel of the lens zoom controller with the zoom ring (This step is not necessary for fixed focal length lenses without a lens zoom controller).

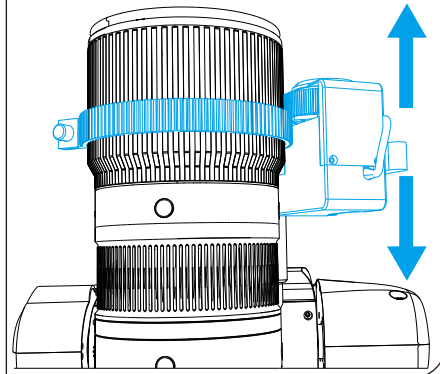

Step 10. Ensure a tight fit between the lens zoom controller and the camera lens zoom gear. The following steps are not needed if using a fixed zoom controller without installing a lens zoom controller,

(1). Loosen the fastening knob counterclockwise.

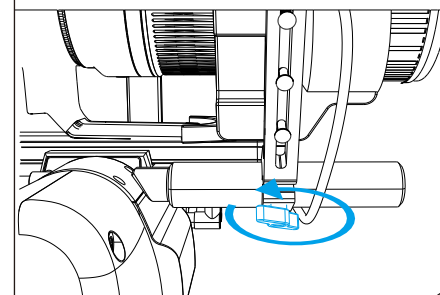

(2). Align the gear on the lens zoom adjuster with the gear on the zoom ring, following the illustrated direction.

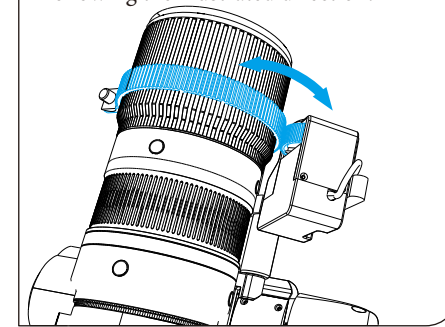

(3). Tighten the lens zoom controller in place

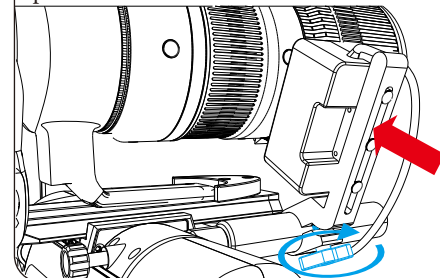

Note: It is important to press down the metal rod of the lens zoom controller with your finger, ensure tight engagement between the two gears before tightening the thumb knob. Pressing on the plastic casing may result in loose engagement.

#### Case 2: Installing the smart gimbal on water or muddy ground

When installing the gimbal on a water surface or muddy terrain, it is necessary to mount the shooting direction base on the tripod at the first. Because it becomes difficult to make adjustment once the tripod is inserted into the muddy ground or water.

Additionally, the process of retrieving items and moving back and forth between muddy paths and water can be quite inconvenient for the user.

Therefore, different installation steps should be taken in such scenarios.

1. Install the shooting direction base.

When installing on a hard floor, it is not necessary to mount the shooting direction base on a tripod.

(1). Mount the shooting direction base on the tripod and tighten it.

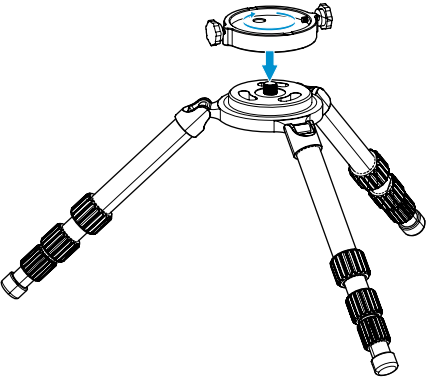

(2). Based on the desired shooting direction at the shooting site, insert the tripod into the water or mud according to the indications on the shooting direction base. Observe the air level and adjust it to ensure its balance.

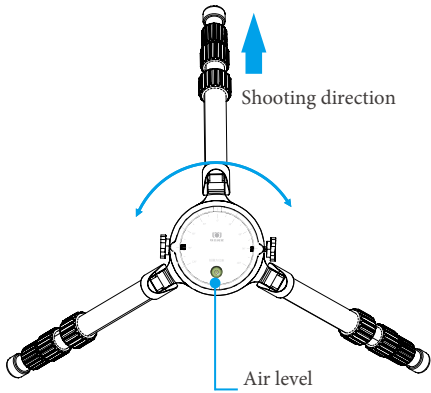

2. Place the smart gimbal on the car seat or a hard surface.

Install the smart gimbal according to the steps described in the first case, and then install the smart gimbal on the tripod at one time.

## Chapter 3. Installation of Remote Camera Assistant mini— Wired control the DSLR camera

### 1. Viewfinder camera Introduction and Illustrations

DSLR camera need a Viewfinder camera when working with RCA mini, with the Viewfinder camera, we can view the displayed images of Viewfinder camera from the RCA mini App, and also can adjust the parameters.

Viewfinder camera:

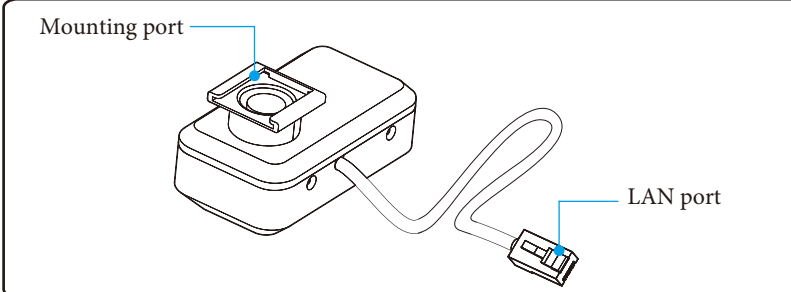

### 2. Viewfinder camera installation method

(1) Before installing the viewfinder camera, you need to remove the viewfinder cover. There are two ways to remove the cover:

① The method of removing the plug-in camera cover is as follows. (Nikon D5, D7500, etc.)

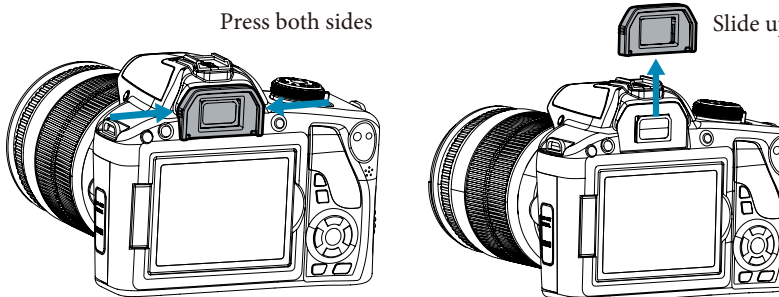

② The method of removing the spiral camera cover is as follows. (Nikon D850, D500, etc.)

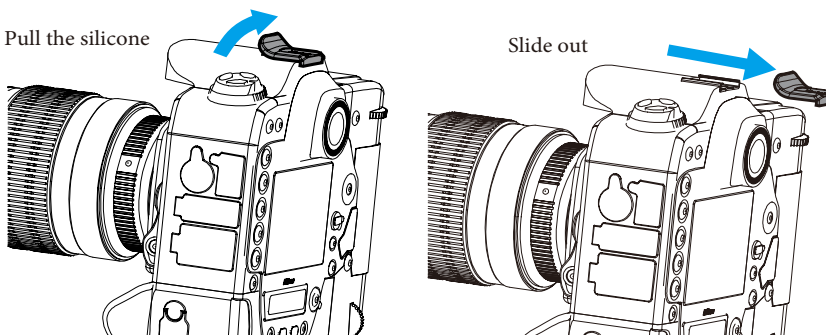

2. Plug-in Viewfinder camera installation  
Align the viewfinder camera with the slot and insert it from top to bottom.

3. Spiral Viewfinder camera installation  
The spiral Viewfinder camera needs a bracket. You need to choose a compatible model.

(1). Loosen the adapter bracket knob clockwise  
(2). Install the bracket onto the camera hot shoe interface and tighten the adapter bracket knob.

(3) Align the viewfinder camera with slot of the fixed bracket and insert it from top to bottom.

Viewfinder camera installed

Plug-in cover      Spiral cover

4. Insert the cable into the network cable port on the far right of the Gimbal .

Compatible model	Qty	Cable	Gimbal side	Camera side	Length
D5、D850、D500	1	HDMI cable	HDMI A	HDMI C	0.35-0.4m
	1	USB cable	USB	USB 3.0	0.35-0.4m
	1	Shutter cable	3.5mm port	N1 shutter port	0.35-0.4m

- This product comes with the data cable required by Z8; it is not equipped with a data cable suitable for DSLR cameras,
- The data cable for D5/D850/D500 is different from that for Z8/Z9, need to order additionally.

### Chapter 4. Installation of RCA mini—Wireless control the mirrorless camera

RCA mini connects to some cameras via Wi-Fi, and uses Nikon SnapBridge App to control camera shooting, and can switch between photos and videos on the APP. Between Nikon camera and mini, only the power cable of the battery converter is connected, making installation simpler and more convenient.

Compatible model : Z9、Z6II

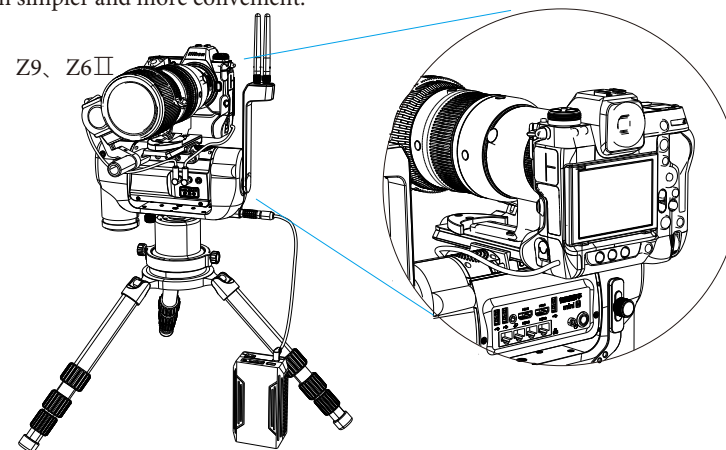



## Chapter 5. On-site debugging of the smart gimbal

1. Install the battery for the signal transmitter at the bottom of the device. Attach the two antennas to the signal transmitter. Open the support bracket at the bottom of the signal transmitter and place it on a suitable surface.
2. Connect the power cable of the signal transmitter to the battery and turn on the power switch.
3. Turn on the tablet/mobile phone and connect to the Wi-Fi signal to establish a stable connection.
4. Connect the operating controller via Bluetooth to ensure a successful connection with the tablet/mobile phone.
5. Open the tablet/mobile phone to display the live view from the camera.
6. Debug various functions on the tablet/mobile phone to ensure they can be operated smoothly.
7. Debug the operating controller's rotation and tilt functions, as well as the lens zoom controller, to ensure that the camera lens zooms properly.
8. Debug the operating controller's focus point movement, focus, shutter button, and camera shutter release function to ensure their proper operation.
9. On the camera body, determine the number of shots for high-speed continuous shooting and the image format (RAW or JPEG). Once determined, the software cannot adjust the number of shots or select the image format.
10. Take photos and record videos to confirm that the shooting and recording are working properly.
11. Leave and proceed to the predetermined shooting location after completing the above steps.

## Chapter 6. Remote preparation for remote shooting

1. Upon reaching the designated location for operating the controller or parking the car, use a rangefinder to ensure the distance is within 500 meters between you and the smart gimbal.
2. Set up the signal transmitter at your end, preferably in a high position to minimize obstacles that may block the communication signal. Ensure there are no significant obstructions between the antennas, ideally with a clear line of sight. If the distance to the camera is over 300 meters, the signal transmitter must be placed at a height of more than 1 meter from the ground.
3. Connect the power cable to the signal transmitter.
4. If the subject is within a safe distance from you, where there is no need for hiding or obstruction, and you will not affect the safety and movement of the subject, then you can stay together with the operating controller, tablet, and signal transmitter.
5. If the subject is not within a safe distance, you need to hide or obstruct yourself, or you need to stay in the car to avoid disturbing the subject's safety and movement, then you can separate from the signal transmitter, with a separation distance of up to 100 meters.
6. Hold the operating controller and tablet behind cover and obstructions (such as inside the car, behind trees, bushes, rocks, etc.), while the signal transmitter with the smart gimbal antennas is set up on a tripod in an unobstructed position and kept separate within a distance of up to 100 meters.

## Chapter 7. On-site debugging of the RCA for remote shooting

Debugging the tablet/mobile phone, software, and operating controller. Please refer to the detailed instructions in the software manual for specific operations. Here is a brief overview:

1. Securely attach the tablet/mobile phone to the operating controller.
2. Turn on the tablet/mobile phone and connect to a Wi-Fi network.
3. Connect the operating controller via Bluetooth.
4. Tap on the Remote camera assistant control software on the tablet/mobile phone, and the real-time display screen will appear by default.
5. Debug the various functions on the tablet/mobile phone to ensure they can all be operated.
6. Debug the operating controller to ensure its functions are working properly.
7. If everything is working properly, you can proceed with the shooting and patiently wait for the subject to appear. If the image from the smart gimbal is not displayed or the operation is not smooth, carefully review the installation steps for any potential issues.

## Chapter 8. Power-saving and sleep mode settings for the RCA mini

### Power-saving and sleep mode settings for the RCA mini

1. In the absence of operating controller and when the gimbal is not running, although the battery life can be extended, the gimbal system is still active, maintaining communication and consuming power.
2. This setting serves two purposes: energy saving for long battery life and timed power on/off of the gimbal. It helps users capture shots during the optimal lighting conditions.
3. The sleep mode setting may be needed in the following situations:
  - (1). The Remote camera assistant is pre-installed at the shooting location instead of installing it on-site before shooting, which minimizes disturbance to animals and birds. [For example, the user sets up the RCA at the chosen shooting location in the evening before (before 6 PM) and schedules it to power on half an hour before sunrise the next morning (around 5:30 AM). This way, the device will automatically power on, and the user can remotely control it for shooting without having to go to the site in person. This approach avoids disturbing animals and saves the user time and effort. Without the sleep mode setting, the device would consume power continuously from 6 PM on the previous day, even though there is no operation, the remaining battery capacity may not be sufficient for shooting the next day.]

(2)After capturing shots in the morning during good lighting conditions, the subsequent lighting, especially during the midday period, becomes too intense, resulting in poor image quality. Without the sleep mode setting, the device would continue to consume power, and by the time the suitable shooting time in the afternoon arrives, the battery capacity may not be sufficient for the desired shooting duration.

(3)If the user needs to stop shooting for a longer period of time, such as eating, resting, a little urgent need to leave for a few hours, etc.

4. The RCA mini relies on wireless communication to connect the two ends of the device to keep be able to operate and the device running. When it goes into sleep, the signal at both ends will be interrupted. Without the wireless signal, it will not be possible to operate the device remotely. If the signal is not interrupted, it means that the device has not entered the sleep state, still running and the device is still constantly consuming power. Therefore, the RCA mini solution is: set the sleep mode time.

5. After the sleep mode, the RCA mini automatically start the power, smart gimbal starts to run and resume transmission of wireless signals. At this time you can operate the tablet / phone and handle, remote control equipment and camera.

6. Specific operation procedure (see the following figure)

- a,Click "sleep mode settings" in the upper right corner of the tablet (sleep mode on the phone is in the lower right corner of More Functions).
- b,In pop-up interface, set the "start time" and "end time".

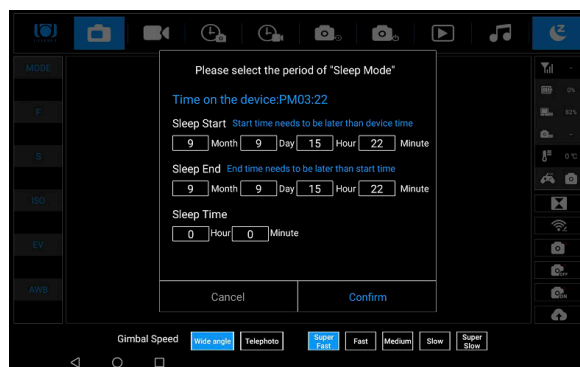

- c. The tablet will automatically calculate the "sleep mode duration".
- d. On the page "Confirm" and "Cancel", if you change your mind, you can click "Cancel".
- e. Click "Confirm", RCA mini starts to enter the sleep mode according to the set time.

7. During sleep mode, the status of the device cannot be changed via the tablet, because there is no communication signal transmission from both ends. You must wait until the sleep time is over, the RCA mini power automatically start, and you can enter the operation after there is communication signal. Unless, you have to manually start the power switch of RCA mini to operate the device. But this will affect the animals at the shooting site, and it is possible to disturb the animals to leave the shooting site resulting in the inability to continue shooting.

8,When setting the sleep mode, please pay attention:

(1). Before setting the sleep mode, according to the needs of shooting, please carefully considering the time of this sleep, so as not to delay the effective shooting.

(2).Check the time of the tablet with the phone and watch.

It is possible that the tablet is not in the mobile network when it is outdoors. Therefore, the time of the tablet may not be consistent with the actual time. Therefore, it is better to check the time of the tablet with your cell phone or watch before setting the sleep time. There are two ways to check and adjust the time:

- a. The tablet is connected to a 4G/5G network by connecting to a mobile hotspot and the time can be adjusted automatically.
- b. If there is no local 4G/5G network, you can directly adjust the time on the tablet to match the time on the watch.

9. To set the hibernate mode, the following conditions must also be met:

The camera must be powered by a battery converter, and is powered by the gimbal for remote power-saving sleep operation.

## Chapter 9. Safety precautions for the RCA mini

For safe use of the product, be sure to read these precautions. Please follow these precautions to prevent damage or injury to user or others. Warning: Indicates a risk of serious injury or dead.

1. Please keep the product out of the reach of children. Power cords, cords and straps wrapped around a person's neck may cause suffocation.
2. It is dangerous to swallow the product parts or accompanying items or accessories. If swallowed, please seek medical attention immediately.
3. Swallowing batteries is dangerous. If swallowed accidentally, seek medical attention immediately.
4. Use only the power source specified in these instructions for use with the product.
5. Do not disassemble or modify the product.
6. Do not subject the product to strong impact or vibration. Do not touch any exposed internal parts.
7. Do not use of the product if there is any abnormality such as smoke or odor.
8. Do not use organic solvents (alcohol, gasoline or paint thinner) to clean the product.
9. Do not get the product wet. Do not insert foreign objects into the product or pour liquid into the product.
10. Do not immerse the battery in water.
11. Do not use the product in an environment where flammable gases may be present. Failure to do so may result in electric shock, explosion or fire.
12. Do not touch the product when it is connected to an electrical outlet during a thunderstorm. Failure to do so may result in electric shock.

13. When using the battery charger or AC adapter, follow the precautions below :  
 When using the battery charger or AC adapter, follow the precautions below :
- (1). Use the battery only for the specified product.
  - (2). Do not heat the battery or expose it to ignition sources.
  - (3). Do not use a battery charger other than the specified one to charge the battery.
  - (4). Do not expose the terminals to dust or contact with metal nails or other metal objects.
  - (5). Do not use leaking batteries.
  - (6). When handling the battery, isolate the terminals with tape or by other means.
  - (7). Do not touch the battery charger or AC adapter connected to the power outlet during a thunderstorm. Failure to do so may result in electric shock, explosion or fire.
  - (8). If the battery leaks and the leaking material comes in contact with skin or clothing, rinse the contact area thoroughly with running water.
  - (9). In case of contact with eyes, rinse thoroughly with plenty of clean running water and seek immediate medical attention.
  - (10). Use a dry cloth to regularly clean all dust accumulated on the power plug and power outlet.
  - (11). Do not plug or unplug the power plug with wet hands.
  - (12). Do not use the product without the power plug fully inserted into the power outlet.
  - (13). Do not expose the power plug and terminals to dust or allow them to come into contact with metal nails or other metal objects.
14. Do not place heavy objects on the power cord. Do not damage, break or modify the power cord.
  15. Do not wrap the product in cloth or other material while the product is in use or when it has just been used and is still
  16. Do not leave the product connected to the power supply for long periods of time when not in use.
  17. Do not charge the battery at temperatures outside the 0-40° C range. Otherwise, it may cause electric shock, explosion or fire.
  18. Do not leave the product in contact with skin in same position for a long time during use.
  19. In places where the use of the product is prohibited, please follow the signs to turn off the product. Otherwise, the influence of electromagnetic waves may lead to the failure of other equipment, and may even cause accidents.
  20. Do not unplug the power supply by pulling on the power cord

△ Attention: Please observe the following precautions. Failure to do so may result in personal injury or property damage.

1. Do not place the product in a high or low temperature environment. The temperature of the product may become high or low and may cause burns or injuries when touched.
2. In addition, do not shake the product or subject it to strong impact.
3. Do not squeeze the product by force or cause it to collide with objects. Doing so may cause injury or damage to the product.

4. Please mount the product only on a tripod or fixture that is sufficiently stable.
5. Do not move the product after it is mounted on a tripod. Failure to do so may cause injury or may result in an accident.
6. Do not touch any parts inside the product. Otherwise, it may cause injury.
7. If an abnormal reaction or inflammation of the skin occurs during or after the use of this product, please stop further use and seek medical attention promptly.

#### Operating precautions: (Maintenance of RCA mini)

1. This equipment is a precision instrument. Do not drop it or expose it to physical impact.
2. This equipment is not waterproof and cannot be used underwater.
3. To prevent sand, dust, dirt or water from accidentally falling on the equipment and getting inside the equipment, the equipment is designed to be dust-proof and drip-proof, but it cannot completely prevent dirt, dust, water or salt from getting inside the equipment. Try not to let dirt, dust, water or salt fall on the equipment.
4. If water falls on the equipment, wipe it off with a clean, dry cloth. If dirt, dust or salt falls on the equipment, wipe it off with a clean, wrung-out damp cloth.
5. Using the product in a dusty or dirty location may cause damage to the equipment.
6. It is recommended to clean the equipment after use. Leaving dirt, dust, water or salt on the equipment may cause equipment failure.
7. If the device accidentally falls into water or if you are concerned that moisture (water), dirt, dust, or salt may have entered the device, contact us immediately.
8. Do not place the product near objects with strong magnetic fields, such as magnets or motors. Also avoid using the device near objects that emit strong radio waves or placing the device close to such objects, such as large antennas. Strong magnetic fields may cause equipment malfunction or damage image data.
9. Do not place the equipment in places where the temperature is too high, such as in a car in direct sunlight. High temperatures may cause the device to malfunction.
10. The equipment contains sophisticated electronic circuitry. Do not disassemble the equipment yourself.
11. Do not use cleaning agents containing organic solvents to clean the body and lens.
12. If condensation occurs on the equipment, do not use the equipment to avoid damage. Please turn off the equipment and wait until all the moisture has evaporated before using it again.
13. If the device is not used for a long time, disconnect the battery and place the device in a well-ventilated, dry and cool place. Please use the device every once in a while during storage to make sure it works properly.

14. Avoid storing the equipment in places where there are chemicals that cause rust and corrosion, such as chemical laboratories.
15. If the equipment has not been used for a long time, test all functions before shooting.

## Chapter 10. Product specifications

Item/Sub-item		Function
Function		Within 500m, In unobstructed or slightly obstructed situations, remotely control the smart gimbal and camera through a tablet and operating handle
Version		Mirrorless version-Standard
		DSLR version-Addition version
Models		Subject to instruction
Components	Mirrorless version	Smart gimbal, signal transmitter, battery, lens zoom controller,operating handle;
	DSLR version	Smart gimbal, signal transmitter, battery, lens zoom controller,operating handle,View finder camera;
	APP	RCA mini ' APP
Communication	Communication rate	5.2-5.8GHz
	Communication distance	The communication distance of smart gimbal and signal transmitter≤500m, No or slight obstruction
		Via upgrade, The communication distance of smart gimbal and signal transmitter≤1000m,
	Bluetooth	The operating handle is connected to the tablet via Bluetooth
Wi-Fi	The camera is connected to the smart gimbal via Wi-Fi	
	The distance between tablet and signal transmitter≤100m	
Smart gimbal control functions	Operating handle control	Rotation and pitching,
	Operating handle control	Drive lens zoom
	APP control	The movement speed can be adjusted; super fast, fast,medium, slow, super slow
	APP control	One click to return to center
Camera control function	APP control	Remotely adjust camera exposure mode and exposure parameters
		Remote camera focus point movement and focusing
		Remote shutter release to take pictures
		Remote camera video recording,
		Remote photo/video mode one-touch switching;
		Camera sleep
		Camera restart
		Smart gimbal and camera timed sleep and start function
		Remotely read some camera pictures for playback and browsing

Other functions	APP control	Music play
		Fan cooling for the device
		Real-time monitoring of system power, camera power, and device temperature
		Firmware and APP software can be upgraded online
Upgrade or customization	Communication distance upgrade	Remote control distance 1000 meters version; upgrade firmware and related accessories to extend the remote control distance
	Upgrade 1	Infrared trigger version; add infrared sensor and control system to achieve full-automatic shooting and remote control shooting two-in-one
	Upgrade 2	Multi-device control version: With one handle and a tablet, the host can connect 2-4 RCA mini and cameras to control shooting at the same time;
Gimbal parameter	Gimbal weight	2.3 kg
	Maximum load	≤4.2kg
	Gimbal size	295*257*105mm
	Working temperature	0-45°C (Same as camera)
	Operating voltage	24V
	Rated Power	16W
	Rated current	1.5A
	Battery life	Standard battery, ≤4.5h (Standby time) ; ≤2.5h (Continuous use) ; Depends on the camera model used
Movement angle	Rotation	Left 130°, right 130°
	Pitch	Down 22°, Up 40°, (Horizontal forward0°)
Environmental indicators	Working temperature	0-45°C (Same as camera)
	Storage temperature	0-40°C( Storage humidity: 20%-60%)
	Waterproof level	Not waterproof
Signal transmitter	Weight	0.475kg
	Dimension	150*110*60mm
	Input voltage	24V
	Channel rate	5.2-5.8GHz
	Transmit power	27dBm
Operating handle	Weight	0.24kg
	Dimension	235*128*45mm
	Signal transmission method	Bluetooth
	Working voltage	DC 3.7V
	Working current	< 15mA
	Battery life	≥15h
	Sleep current	< 15 μA
	Charging voltage/ current	DC5V/500mA
	Battery capacity	380mH



Battery	Model	UB04	
	Battery type	Rechargeable lithium-ion battery	
	Versatility	Standard battery for smart gimbal and signal transmitter	
	Capacity	82.88Wh	
	Nominal voltage	24V	
	Battery dimension	138mm*80mm*39mm	
	Battery weight	418g	
	Charging voltage	29.4V	
	Charging time	Standard charging 4 hours	
		Fast charging 2 hours	
Charging current	Standard charging 0.2C		
	Fast charging 0.5C		
Working temperature	Charging temperature 0-45°C		
	Discharging temperature -20-60°C		
Packing	Carton	1PC/ctn	
	Inner box dimension	356*268*248mm	
	Carton dimension	450*300*305mm	
	Packing method	EPE + waterproof cloth bag+carton	
	Inner box material	EPE + waterproof cloth bag	
	Carton material	Corrugated paper + kraft paper	

## Chapter 11. Power supply specifications and maintenance

### 1. Specifications of battery selection

Battery name	UB-01 battery (Optional)		
Battery type	Rechargeable lithium-ion battery	Capacity	372Wh
Normal voltage	25.9 V	Charging voltage	29.4 V
Charging current	Standard charging 0.2C	Charging time	Standard charging 6h
	Fast charging 0.5C		Fast charging 4.5h
Operating temperature	Charging: 0°C-45°C	Battery size	155mmX88mmX76mm
	Discharging: -20°C-60°C		Battery weight

### 2. Battery usage time table:

Battery	Qty	Usage time		Feedback	Solution
		Gimbal/camera Non-stop use	Standby		
Signal transmitter battery	1	24H		Enough	
82.88Wh Standard battery	1	2-2.5H	4-4.5H		Battery manager, 2-6 batteries auto-replacing use to meet the ultra long battery life
372 Wh Large battery	1	11-13H	20H	Extend battery life	
Tablet	1	6H			Carry a power bank, fully charge before departure.
Operating handle	1	40H			Carry a power bank

Note: When used at temperatures below -5 °C, Battery life will decrease as temperature decreases.

### 3. Battery life solution introduction

#### (1). Battery manager

The Battery manager is a tool that combines multiple batteries for sequential power supply. It can accommodate up to 6 batteries (82.88 Wh batteries or 372 Wh high-capacity batteries). Following the numerical order, once the first battery is depleted, the system seamlessly switches to the second battery, providing uninterrupted power during the transition. You don't have to worry about running out of power.



If a total of 3 batteries are connected, after the first and second batteries are depleted, the system will start using the third battery. Then you can remove the first battery for charging. Once charging is complete, reconnect the battery to the first power port of the Battery manager. When the third battery is depleted, the system will automatically switch back to the first battery to continue providing power.

(2). Battery manager layout diagram for connecting UB04 batteries with 6 x 82.88 Wh standard batteries:

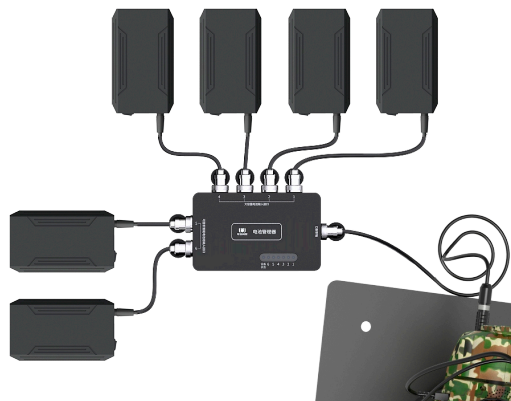

(3). Battery manager layout diagram for connecting UB01 batteries with 6 x 372 Wh standard batteries:

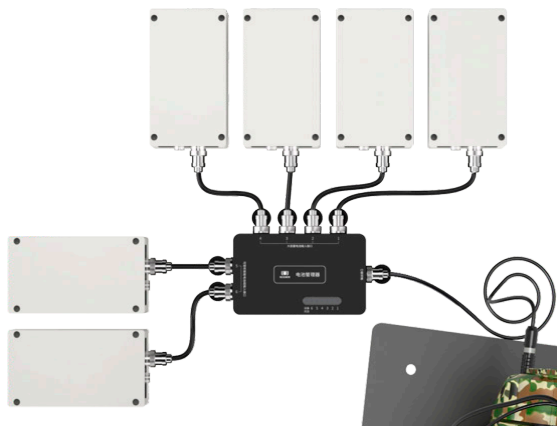

4. Precautions for battery use:

(1). Charge

- When using the included adapter to charge the battery, the indicator light on the adapter will display red.
- It is necessary to first switch the power button to the discharge state "-" before charging.
- During the charging process, please keep the battery placed stably and pay attention to ventilation and heat dissipation.
- The light will turn to green after fully charged, never charge the battery for a long time after it is fully charged.
- When the battery level is below 25%, it is advisable to charge it promptly.

(2). Discharge

- Use the included aviation plug cable, one end connected to the battery discharge port, one end connected to the Remote camera assistant mini power interface. Turn on the battery switch to discharge.
- Discharge will generate heat, if used outdoors in strong light, please put the battery in the shade, and pay attention to ventilation and heat dissipation.
- When the tablet displays a low battery alert signal, please try to turn off the power to avoid over-discharge.

(3). Battery maintenance

To prolong the life of the battery, please maintain it as follows:

- The lithium battery needs to be placed at a suitable temperature, 25 °C is appropriate.
- The charging method of lithium battery is the most important among the correct usage of lithium battery. Incorrect charging method can cause safety problems; correct discharge and daily maintenance can extend the life of the battery.
- Use the matching adapter for charging. Too high charging voltage will overcharge the battery, and vice versa, undercharge will occur.
- If the battery has not been used for a long time (e.g. 30 days), the user must remember to complete a deep charge and discharge cycle for the lithium battery once a month.

## Chapter 12 Wireless communication

- Wireless LAN data and restrictions, when using wireless networks, please be sure to follow local regulations.
- Operating frequency range: 5150- 5350 MHz
  - Equivalent isotropic radiated power (EIRP) : $\leq 200$  mW
  - Maximum power spectral density : $\leq 10$  dBm / H
  - Carrier frequency tolerance: 20 ppm
  - Broadband external transmit power:  $\leq 80$  dBm / Hz:
  - Spurious emission (radiated) power: 0~ 1000 MHz)
    - $\leq -54$  dBm/ 100kHz (48.5 ~72.5 MHz .76~118 MHz 167~223 MHz. 470~798 MHz)
    - $\leq -40$  dBm / 1 MHz (2400~ 2483.5 MHz)
    - $\leq -33$  dBm / 100KHz( 5150~5350 MHz)
    - $\leq -40$  dBm / 1 MHz (5470 ~5850 MHz)
    - $\leq -30$  dBm / 1 MHz(Other 1~40GHz)

3. Operating frequency range: 5725~5850 MHz

- Transmission power: ≤500 mW and ≤27 dBm
- Equivalent isotropic radiated power (EIRP) : ≤2W and ≤33 dBm
- Maximum power spectral density: ≤13 dBm/ MHz and ≤9 dBm / MH (EIRP)
- Carrier frequency tolerance: 20 ppm
- Broadband external transmit power: ≤-80 dBm/ Hz (≤5725 MHz or 5850 MHz)
- Spurious emission (crystal emission) power:
  - ≤36 dBm/ 100 KHz (30~ 1000 MHz)
  - ≤-40 dBm/1 MHz (2400~ 2483.5 MHz)
  - ≤-40 dBm/1 MHz (3400~ 3530 MHz)
  - ≤-33 dBm / 100 KHz (5725~ 5850 MHz)
 (Note: 2.5 times the channel bandwidth of the corresponding carrier) ≤-30 dBm/1 MHz (Other 1~ 40 Ghz)

Note:

1. Do not change the transmission power without authorization, increase the transmission power (including additional RF power amplifiers), and do not connect external antennas or use other transmission antennas without authorization;
2. Do not cause harmful interference to various legal radio communication services during use: once any interference is found, stop using it immediately and take measures to eliminate the interference before continuing to use it;
3. The use of micro-power radio equipment must endure interference from various radio services or radiation interference from industrial, scientific and medical application equipment;
4. Not for use near airplanes and airports.

## Chapter 13. Product Certification and Compliance

### 1. Certification

The batteries used in this device have passed national safety standard tests and will also undergo CCC certification according to the latest national requirements (before August 1, 2024). The charger used has already obtained CCC certification (for related certifications, please refer to the UELERET official website ).

## 2. The name and content of harmful substances in the product.

Name of parts	Harmful substances					
	Lead (Pb)	Mercury (Hg)	Cadmium (Cd)	Hexavalent Chromium (Cr(VI))	(PBB)	(PBDE)
Plastic parts	O	O	O	O	O	O
Metal parts	O	O	O	O	O	O
Circuit board components	X	O	O	O	O	O
Touchpad	O	O	O	O	O	O
Internal wires	O	O	O	O	O	O
External wires	O	O	O	O	O	O
Package material	O	O	O	O	O	O
Accessories	O	O	O	O	O	O
Battery	X	O	O	O	O	O
Print	O	O	O	O	O	O

This table is prepared in accordance with the provisions of SJ/T 11364

O : Means the content of the hazardous substance in all homogeneous materials of the part is below the limit requirement specified in GB/T 26572

X : It means that the content of the hazardous substance in at least one homogeneous material of the part exceeds the limit specified in GB/T 26572



People's Republic of China  
Restricted Use Mark for Hazardous  
Substances in Electrical and  
Electronic Products

This mark applies to electrical and electronic products sold in the People's Republic of China, and the number in the center of the mark represents the environmental use period of the product. As long as you observe the safety and usage precautions related to this product, there will be no environmental pollution or serious impact on human body and property within the above mentioned period of time from the date of manufacture.

## Chapter 14 Remote camera assistant mini 1000m version

1. It refers to the wireless communication distance of 1000 meters when the signal is unblocked or slightly blocked. The Remote camera assistant mini1000 product can be obtained through the following methods:

The owner purchased the Remote camera assistant mini, and then pay to download the firmware and purchased the communication package to upgrade to the Remote camera assistant mini 1000.

### 2. Usage schematic diagram of Remote camera assistant mini1000

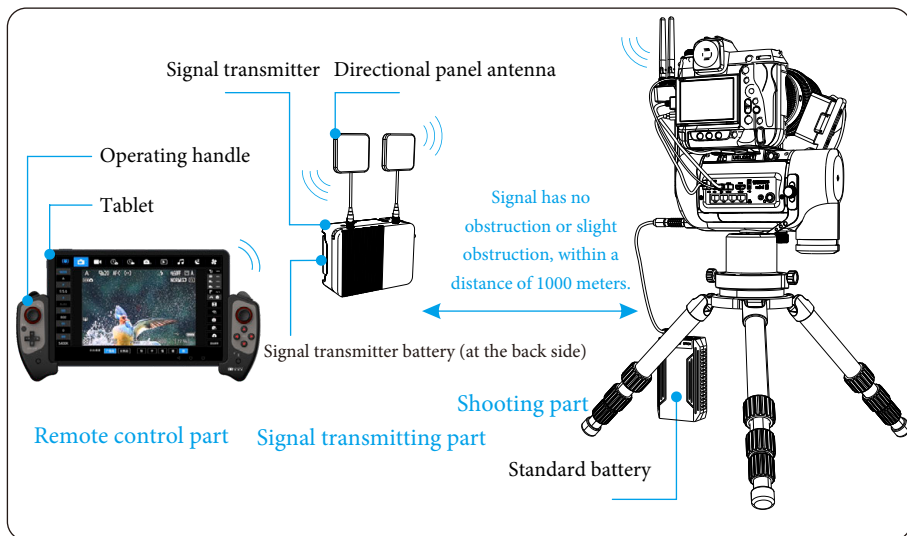

3. The installation method of mini1000 and mini are same, please refer to page 10.

### 4. Omnidirectional Antennas and Directional Antennas

(1). The Signal transmitter of 500 meters communication distance are working with omnidirectional antenna

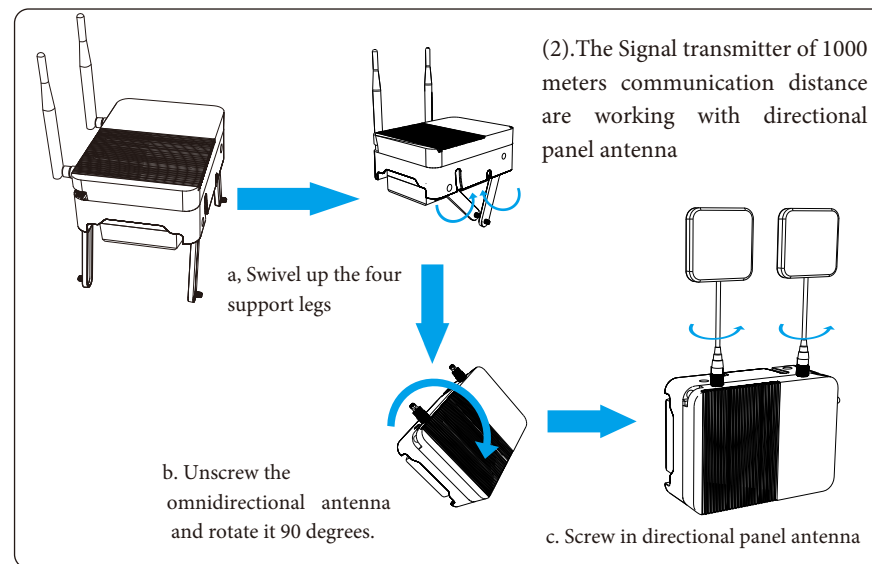

### (3). Directional flat panel antenna installation requirements

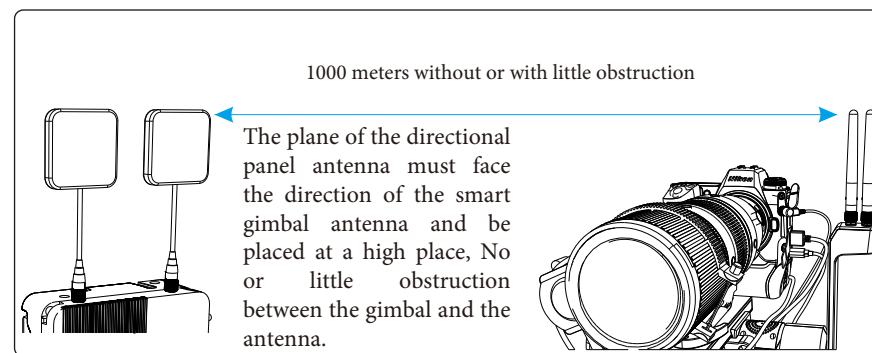

Disclaimer: As this product is an original patented product, there may be changes in its features or specifications in the future. In the event of any changes, please refer to the official website of our company. UELERET reserves the right to interpret any changes.